



TEREX



CAL CRANE & EQUIPMENT

Tel: 1 (844) 882-2415 • Fax: 1 (510) 639-4053
crane-sales@calcrane.com • www.calcrane.com

Truck Crane Specifications | T500-1 Series

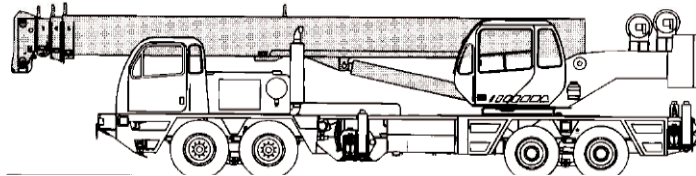

STANDARD BOOM EQUIPMENT

BOOM

35-110' (10.67 - 33.53 m), four section full power, mechanically synchronized boom. High-strength four plate construction with embossed side plate holes to reduce weight and increase strength. Anti-friction slide pads. A single boom hoist cylinder provides for boom elevation of -4° to 76°. Maximum tip height is 114' (34.75 m)

BOOM HEAD

Welded to outer section of boom. Four or five non metallic load sheaves and two idler sheaves mounted on heavy duty, anti-friction bearings. Quick reeving boom head. Provisions made for side-stow jib mounting.

OPTIONAL BOOM EQUIPMENT

JIBS

33' (9.75 m) side stow swing-on one-piece lattice type jib. Single sheave mounted on anti-friction bearing. Jib is offsettable at 0°, 15° or 30°. Maximum tip height is 145' (44.22 m) with 110' (33.53 m) boom.

33-57' (10.16 - 17.37 m) side stow swing-on lattice type jib. Single sheave mounted on anti-friction bearing. Jib is extendible to 57' (17.37 m) by means of a 25' (7.32 m) manual pull-out tip section, roller supported for ease of extension. Jib is offsettable at 0°, 15° or 30°. Maximum tip height is 169' (51.62 m) with 110' (33.53 m) boom.

AUXILIARY BOOM HEAD

Removable auxiliary boom head has single sheave mounted on anti-friction bearing. Removable pin-type rope guard for quick reeving. Installs on main boom peak only. Removal is not required for jib use.

HOOK BLOCK

Three, four or five nylon sheaves on anti-friction bearings with hook and heavy duty hook latch. Quick reeving design does not require removal of wedge and socket from rope.

HOOK AND BALL

7 ton (6.3 mt) top swivel ball with hook and hook latch.

STANDARD UPPERSTRUCTURE EQUIPMENT
UPPERSTRUCTURE FRAME

All welded one-piece structure fabricated with high tensile strength alloy steel.

COUNTERWEIGHT

Integral counterweight removal system permits counterweight to be carried on the deck of the carrier to optimize axle weights and multiple counterweight combinations to be utilized.

TURNTABLE CONNECTION

Swing bearing is a single row, ball type, with internal teeth. The swing bearing is bolted to the revolving upperstructure and to the carrier frame.

SWING

A hydraulic motor drives a double planetary reduction gear for precise and smooth swing function. Swing speed (no load) is 2.8 rpm.

SWING BRAKE

Heavy duty multiple disc swing brake is mechanically actuated from operator's cab by foot pedal. Brake may be locked on or used as a momentary brake.

RATED CAPACITY INDICATOR

Rated Capacity Indicator with visual and audible warning system and automatic function disconnects. Pictographic display includes: boom radius, boom angle, boom length, allowable load, actual load, and percentage of allowable load registered by bar graph. Operator settable alarms provided for swing angle, boom length, boom angle, tip height, and work area exclusion zone. Anti-two block system includes audio/visual warning and automatic function disconnects.

OPERATORS CAB

Environmental cab with all steel construction, optimum visibility, tinted safety glass throughout, and rubber floor matting is mounted on vibration absorbing pads. The cab has a sliding door on the left side, framed sliding window on the right side, hinged tinted all glass skylight and removable front windshield to provide optimum visibility of the load open or closed. Acoustical foam padding insulates against sound and weather. Hot air defroster keeps windshield clear. The deluxe six-way adjustable operator's seat is equipped with a torsion bar suspension and includes head and arm rests.

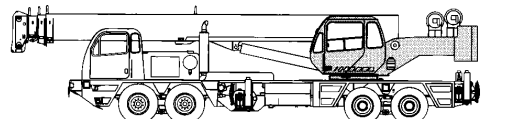
CONTROLS

Armrest mounted dual axis controls for winch(s), swing, and boom elevation. Winch rotation indication incorporated into control handles. Armrest swings up to improve access and egress. Vernier adjustable hand throttle included. Switches include ignition, engine stop, lights, horn, windshield wipers, defroster, outriggers, 360° house lock, etc. Horn and winch speed shift switches are mounted in the levers. Foot control pedals include swing brake, boom telescope, and throttle.

INSTRUMENTATION AND ACCESSORIES

In-cab gauges include bubble level, engine oil pressure, fuel, engine temperature, voltmeter. Indicators include high coolant temperature/low engine oil pressure audio visual warning, low coolant level audio visual warning, and Rated Capacity Indicator. Accessories include fire extinguisher, windshield washer/wiper, skylight wiper, left & right hand rear view mirrors, dash and dome lights, and seat belt. Circuit breakers protect electrical circuits.

HYDRAULIC CONTROL VALVES

Valves are mounted on the rear of the upperstructure and are easily accessible. Valves utilize electric over hydraulic operators and include one pressure compensated load sensing two spool valve for boom elevation and telescope, one pressure compensated load sensing two spool valve for main and auxiliary winch, and one single spool valve for swing. System provides for simultaneous operation of all crane functions. High pressure regeneration feature provides two-speed boom extension. Quick disconnects are provided for ease of installation of pressure check gauges.

OPTIONAL EQUIPMENT

Auxiliary Winch • LP Heater/Defroster • Hydraulically Powered Air conditioner, Tachometer • Work Lights, Heavy Counterweight Package w/Hydraulic Removal System • Extra Heavy Counterweight Package w/Hydraulic Removal System • Digital AM/FM Cassette Radio

STANDARD CARRIER EQUIPMENT
CARRIER CHASSIS

Chassis is Terex designed and built with an 8 x 4 drive. Triple box construction frame with internal diaphragms is fabricated from high strength alloy steel and provides superior frame rigidity. Full aluminum decking improves access and reduces weight. Multiple lockable storage compartments and ground level outrigger controls are built into decking. Aluminum engine housing with sliding cover optimizes engine access while reducing weight and improving corrosion resistance. Mud flaps.

AXLES AND SUSPENSION

Rear Axles - 42,000 lb (19 057 kg) capacity tandem axles with heat treated housings have inter-axle differential with lockout. Axles are mounted on standard air suspension system over equalizer beams with shock absorbers to distribute weight evenly.

Front Axles - 42,000 lb (19 051 kg) capacity tubular beam type axles are mounted on standard air suspension system over equalizer beams with shock absorbers.

TIRES

Front: Four 425/65R22.5-18 PR. All-position type tubeless.
Rear: Eight 11 R22.5-14PR. deep tread drive axle type tubeless

BRAKES

Full air brakes on all wheels with ABS split circuit system
Front brakes: 16.5 x 6" (419 x 152 mm)
Rear brakes: 16.5 x 7" (419 x 178 mm)
All brakes are air operated "S" cam type with automatic slack adjusters. Lining areas are 768 in² (4954 cm²) front and 920 in² (5935 cm²) rear. Air compressor has standard air dryer. Rear tandem axles have spring-set,

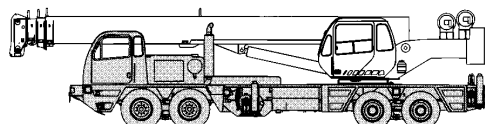

air released parking or emergency brake chambers. Parking brake is applied with valve mounted on dash panel. Emergency brakes apply automatically when air pressure drops below 60 psi (4.2 kg/cm²)

STEERING

Mechanism includes rack and pinion with integral hydraulic power.

Turning radius: To CL of tires
33'-4" (10.16 m)

TRANSMISSION

Standard: Eaton/Fuller 10 speed manual transmission.
Optional: Allison 4500RDS automatic transmission has 6 speeds forward and 1 reverse, with neutral safety start. Provides wide ratio coverage with "hands free" shifting. A lock up torque converter further improves performance.

MULTI-POSITION & DOWN OUTRIGGERS

Fully independent hydraulic outriggers may be utilized fully extended to 21' (6.40 m), in their 1/2 extended position, or fully retracted. Removable aluminum outrigger pads are 452 in² (2919 cm²) and stow on the carrier frame. Complete controls and sight leveling bubble are located in the operator's cab. Additional optional ground level controls are incorporated into the aluminum decking. Includes 5th, front outrigger which incorporates a self stowing permanently attached float



ROUGH TERRAIN CRANE T500-1 SERIES

STANDARD CARRIER EQUIPMENT (CONTINUED)

CARRIER CAB

One-man aluminum cab is mounted on vibration absorbing pads and has optimum visibility, safety glass, acoustical foam padding inside cab for insulating against sound and weather, hot air defroster, six-way adjustable torsion bar suspension seat with seat belt and lockable door with roll down window.

CONTROLS

Included are transmission shift, inter-axled differential lock, cruise control, parking brake, two-speed windshield wiper/washer, heater and defroster, lights, headlight dimmer, dome light, and ignition switch.

INSTRUMENTS

Included are speedometer, hour meter, tachometer, voltmeter, fuel gauge, engine oil pressure gauge, water temperature gauge, dual air pressure gauges. Warning lights include low coolant level, parking brakes on, low air, pumps engaged, and high beam lights.

HYDRAULIC SYSTEM

HYDRAULIC PUMPS

Triple pump driven from engine flywheel housing PTO with air shifted mechanical pump disconnect at 1.3 times engine speed, w/manual or double and single pumps driven by hot-shift PTO's w/automatic. A separate steering pump is driven directly from the engine. Combined system capacity is 115 gpm (435 lpm). Hydraulic oil cooler is standard.

- ▶ **Main and auxiliary winch pump**
60.3 gpm (228.3 lpm) @ 3,500 psi (246.1 kg/cm²)
- ▶ **Boom Hoist and Telescope Pump**
45.1 gpm (170.71 lpm) @ 3,500 psi (246.1 kg/cm²)
- ▶ **Outrigger and Swing Pump**
22 gpm (83.2 lpm) @ 2,500 psi (175 kg/cm²)
- ▶ **Power Steering Pump**
8 gpm (30.3 lpm) @ 1,500 psi (105.5 kg/cm²)

ENGINE SPECIFICATIONS

Make and Model	Detroit Diesel Series 60
▶ Type	6 Cylinder
▶ Bore and Stroke	5.12 x 6.30" (130 x 160 mm)
▶ Displacement	778 cu. in. (12.7 L)
▶ Max. Gross Horsepower	430 hp (320 kw) @ 2100 rpm
▶ Max. Gross Torque@rpm	1450 lb•ft. (1966 N.m)@1200 rpm
▶ Max. Net Horsepower	392 hp (292 kw) @ 1600 rpm
▶ Aspiration	Turbocharged & Aftercooled
▶ Electrical System	12 volt
▶ Alternator	130 amp
▶ Battery @ 0°F	(3) 12V-950 C.C.A
▶ Fuel Capacity	100 gal (379 l)

(Includes standard engine controlled ether starting aid, and Jacobs Brake)

MAIN WINCH SPECIFICATIONS

Hydraulic winch with bent axis piston motor and planetary reduction gearing provides 2-speed operation with equal speeds for power up and down. Winch is equipped with an integral automatic brake, grooved drum, tapered flanges, standard cable roller on drum, and electronic drum rotation indicator.

Performance	LO-Range	HI-Range
▶ Max line speed (no load)		
▶ First layer	184 fpm (56.1 m/min)	369 fpm (112.5 m/min)
▶ Fifth layer	266 fpm (81.1 m/min)	533 fpm (162.5 m/min)
▶ Max. line pull-first layer	15,639 lb (7 093 kg)	7,298 lb (3 310 kg)
▶ Max. line pull-fifth layer	10,827 lb (4 911 kg)	5,052 lb (2 291 kg)
▶ Permissible line pull	9,000 lb (4 082 kg)	

ACCESSORIES

Included are fire extinguisher, right hand and left hand rear view mirrors, electric horn, access steps and grab handles (located at four separate locations around the crane), back-up alarm, two position boom rack, front and rear towing loops.

LIGHTS

Light package includes headlights with foot operated dimmer switch, clearance lights, tail lights, directional signal lights, four-way hazard flasher lights, back-up lights with audible alarm.

OPTIONAL EQUIPMENT

Spare Tire with Wheel, Immersion Heater(s), Pintle Hook, Cold Weather Kit, Series 60 Detroit Diesel Engine w/Allison 4500RDS Automatic Transmission and Jacobs Brake, Air Conditioner, Ground Level Outrigger Controls, Digital AM/FM Cassette Radio

FILTRATION

Full flow oil filtration system with bypass protection includes a removable 60 mesh (250 micron) suction screen-type filter and five micron replaceable return line filter.

HYDRAULIC RESERVOIR

All welded construction with internal baffles and diffuser. Provides easy access to filters and is equipped with an external sight level gauge. The hydraulic tank is pressurized to aid in keeping out contaminants and in reducing potential pump cavitation. Capacity is 117 gal (443 liters).

Drum Dimensions

- ▶ 10.62" (270 mm) drum diameter
- ▶ 22.42" (570 mm) length
- ▶ 20.0" (508 mm) flange dia.
- ▶ Cable: 5/8" x 500' (16 mm x 152.4 m)
- ▶ Cable type: 5/8" (16 mm) 6 x 19 IWRC IPS, right regular lay, performed.
- ▶ Min. breaking strength 17.9 tons (16.2 mt)

Drum Capacity

- ▶ Max. Storage: 561' (171 m)
- ▶ Max. useable: 561' (171 m)*

*Based on minimum flange height above top layer to comply with ANSI B30.5

OPTIONAL AUXILIARY WINCH

Hydraulic 2-speed winch with bent axis piston motor, equal speed power up and down, planetary reduction with integral automatic brake, grooved drum with tapered flanges, drum roller, and rotation indicator.

Performance

- ▶ Max. line speed (no load) - Fifth layer 533 fpm (162.5 m/min)
- ▶ Max. line pull - First layer 15,639 lb (7 093 kg)

Drum Dimensions and Capacity

(Same as main winch)

OPTIONAL HOIST LINE

Main winch and optional auxiliary winch - 5/8" (16 mm) rotation resistant compacted strand 18 x 19 or 19 x 19. . Min breaking strength 22.6 tons (20.6 mt).

SPEED AND GRADEABILITY

Engine	Transmission	Speed Range	Gradeability
60 Series	Manual	65 mph (105 km/h)	100+%
60 Series	Allison	65 mph (105 km/h)	100+%

Performance data is based on a gross vehicle weight of 75,000 lb (34 014 kg). Performance may vary due to engine performance, weight, tire size, etc. Gradeability data is theoretical and is limited by tire slip, stability, oil pan angle, etc.



GENERAL DIMENSIONS

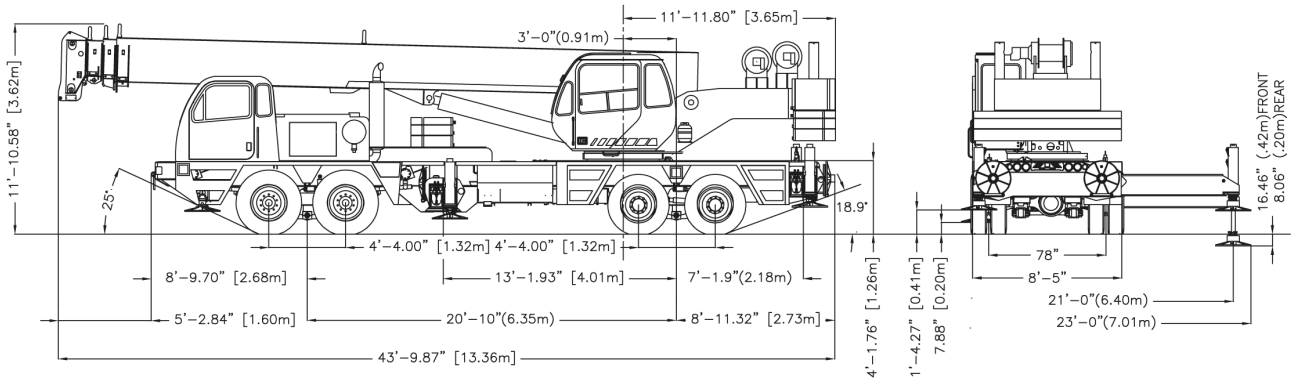

WEIGHTS & AXLE LOADS	GROSS WEIGHT LB	UPPER IN TRAVEL POSITION		GROSS WEIGHT KG	UPPER IN TRAVEL POSITION	
		FRONT	REAR		FRONT	REAR
Basic Crane with 60 Series Engine, 110' (33.52 m) Boom, 360° Mechanical House Lock, 4,000 lb (1 836 kg) Cwt, 1/4 tank of fuel, 425/65R22.5 Load Range L Front & 11R22.5 14 Load Range G with Aluminum Disc Wheels, and 200 lb operator in cab	71,824	33,512	38,311	32,967	15,382	17,585
Add options						
32' (9.68) Swing-on jib	+ 1,270	+ 1,194	+ 76	+ 583	+ 548	+ 35
33'-57' (10.7m-17.37m) Swing on jib	+ 2,170	+ 1,922	+ 248	+ 996	+ 882	+ 114
Auxiliary Boom Head	+ 100	+ 168	- 68	+ 46	+ 77	- 31
3,000 lb Counterweight Slab on Superstructure	+ 3,000	- 1,102	+ 4,102	+ 1,360	- 500	+ 1,860
4,000 lb Counterweight Slab on Superstructure	+ 4,000	- 1,470	+ 5,470	+ 1,814	- 667	+ 2,481
5,000 lb Counterweight Slab on Superstructure	+ 5,000	- 1,837	+ 6,837	+ 2,267	- 833	+ 3,101
3,000 lb Counterweight Slab on Crane Deck	+ 3,000	+ 1,974	+ 1,026	+ 1,360	+ 895	+ 465
4,000 lb Counterweight Slab on Crane Deck	+ 4,000	+ 2,633	+ 1,367	+ 1,814	+ 1,194	+ 620
5,000 lb Counterweight Slab on Crane Deck	+ 5,000	+ 3,291	+ 1,709	+ 2,267	+ 1,493	+ 775
Full Tank of Fuel	+ 545	+ 244	+ 301	+ 250	+ 112	+ 138
Aux Winch with Drum Roller and Wire Rope	+ 87	+ 51	+ 36	+ 40	+ 23	+ 17
Heater/Defroster (Upper)	+ 60	+ 4	+ 56	+ 28	+ 2	+ 26
Work Lights	+ 35	+ 8	+ 27	+ 16	+ 4	+ 12
Pintle Hook (Rear)	+ 100	- 30	+ 130	+ 46	- 14	+ 60
Electric Remote Control	+ 200	+ 100	+ 100	+ 92	+ 46	+ 46
60 ton (45.3 mt) Quick Reeving Hook Block (Tied to Bumper - 5 Sheave)	+ 1,157	+ 1,839	- 688	+ 531	+ 844	- 316
40 ton (36.7 mt) Quick Reeving Hook Block (Tied To Bumper - 4 Sheave)	+ 690	+ 1,104	- 412	+ 317	+ 507	- 189
7 Ton (6.3 mt) Hook and Ball (Tied to Bumper)	+ 340	+ 383	+ 143	+ 156	+ 176	+ 66
Spin Resistant Wire Rope (Main Winch)	+ 90	- 19	+ 109	+ 41	- 9	+ 50
Spin Resistant Wire Rope (Aux Winch)	+ 90	- 27	+ 117	+ 41	- 12	+ 54
Air Conditioning (Lower Cab)	+ 100	+ 112	- 12	+ 46	+ 51	- 6
Air Conditioning (Upper Cab)	+ 150	- 8	+ 158	+ 69	- 4	+ 73

Note: Weights are for Terex supplied equipment and are subject to 2% variation due to manufacturing tolerances.

TEREX Cranes
106-12th Street S.E.
Waverly, Iowa 50677-9466 USA

TEL (319) 352-3920 FAX (319) 352-5727
EMAIL inquire@terexwaverly.com
WEB terex.com

WE RESERVE THE RIGHT TO AMEND THESE SPECIFICATIONS AT ANY TIME WITHOUT NOTICE. THE ONLY WARRANTY APPLICABLE IS OUR STANDARD WRITTEN WARRANTY APPLICABLE TO THE PARTICULAR PRODUCT AND SALE. WE MAKE NO OTHER WARRANTY, EXPRESSED OR IMPLIED.