



**CAL CRANE &
EQUIPMENT**

Tel: 1 (844) 882-2415 • Fax: 1 (510) 639-4053
crane-sales@calcrane.com • www.calcrane.com



TEREX | AMERICAN

HC 110

Hydraulic Crawler Crane



FEATURES

- **110 tons (100 mt) max lift capacity**
- **230 ft. (70 m) max main boom length**
- **200+70 ft. (61+21 m) max lift crane boom & jib length**
- Power up/down and freefall on main and auxiliary drums
- 40,640 lbs. (18 435 kg) max single line pull, 565 fpm (172 mpm) max line speed
- Quiet, comfortable operator's cab with excellent viewing range
- Shockless stop system gradually retards operating speed to reduce shocks when crane approaches lifting load or boom limits
- Two speed travel allows operator to select the best speed and power control for any condition
- Superior transportability:
11 ft. (3.35 m) width
11 ft. 3 in. (3.43 m) height
- 99,400 lbs. (45 100 kg) transport weight including sideframes and boom inner. Transports with full boom and jib on only 4 trucks
- Hydraulic counterweight removal system simplifies installation and removal

THE ULTIMATE CRANE™

Machines shown may have optional equipment.

AMERICAN HC 110

Hydraulic Crawler Crane

Max. Lifting Capacity:
110 tons (80 mt)



Environmental operator's cab



Hydraulic removable counterweight system

230 ft. (70 m) MAXIMUM LIFT CRANE BOOM

- 59HI tubular chord boom, pin connected.
- 25 ft. (7.6 m) inner and outer and 10/20/40 ft. (3/6/12 m) available inserts provide boom compositions in 10 ft. (3 m) increments from 50 ft. (15.2 m) to 230 ft. (70 m).

ENVIRONMENTAL OPERATOR'S CAB

- Designed to provide excellent viewing range and quiet, comfortable operation.
- 37 in. (.91 m) wide cab has wide curved windows on both top and bottom.
- Easy-to-operate modular and ergonomically designed controls reduce operator fatigue and increase productivity.
- Load Moment Indicator with interactive screen features a shockless stop system. Operator can select from three display modes: loaded condition diagram, rated lifting curve, and rated lifting load table.
- Adjustable operator's seat, radio, air conditioner, overhead window, sun visor, fan, overhead and front wipers, and drum rotation indicators standard.

HEAVY DUTY CARBODY AND CRAWLERS

- Fabricated steel carbody is deep box constructed with square axles for the crawler side frames. Precision machined top supports anti-friction swing circle and multiple pass hydraulic swivel joint.

- Crawlers have high alloy steel tumbler yokes and rigid fabricated structures with built-in sealed automatic lubrication system.
- 36" (914 mm) crawler shoes.
- Travel mechanism is set within shoe width.
- Side frames extended or retracted by cylinders inside the carbody.
- Two travel speed settings – 0.60/0.87 mph (0.96/1.4 km/h).
- 30% (17°) gradeability.

POWERFUL, HIGH-SPEED HOIST SYSTEM

- Independent main and auxiliary load hoisting drums. Main drum is grooved for 1 in. (25 mm) diameter rope. Max line speed is 513 fpm (156 m/min), max single line pull is 40,640 lbs. (18 435 kg). Rated single line pull is 29,500 lbs. (13 381 kg). Auxiliary drum is grooved for 7/8 in. (22.4 mm) diameter rope. Max line speed is 553 fpm (168 m/min), max single line pull is 37,670 lbs. (17 086 kg). Rated single line pull is 22,700 lbs. (10 297 kg). Freefall on main and auxiliary drums.
- Each drum, including optional third, has power up/down. Load hoists are further controllable in stepless mode.
- Ample work space in front of drums allows easy access for cable installation and maintenance.
- External contracting brake.
- Internal expanding band clutch.
- 3.0 rpm swing speed.

HIGH CAPACITY, DEPENDABLE HYDRAULIC SYSTEM

- Open circuit system has 5 variable displacement piston pumps with system capacity of 183 gpm (692 lpm).
- Hydraulic reservoir with 79 gal. (300 l) capacity and 10 micron filtration.
- Component working range is between -4 and 203° F (-20 and 95° C).
- 230 HP (171 kW) @ 2000 RPM Cummins 6CTA 8.3 turbocharged diesel engine. Fuel tank capacity is 105 gal. (397 l).

FOUR PIECE REMOVABLE COUNTERWEIGHT

- Four piece pin connected counterweight can be assembled or disassembled easily within minutes.
- Hydraulic counterweight removal system is standard and makes the HC 110 one of the most transportable cranes in its class.
- Moves on four trucks with full boom and #9HL jib. At 17 ft. 0.5 in. (5.2 m) wide and 11 ft. (3.35 m) high, the basic HC 110 will transport on a standard lowboy trailer.

OPTIONS INCLUDE:

- Third drum.
- Automotive type lights.
- Hydraulic power take off.
- Jib and jib inserts.

For more information, product demonstration, or details on purchase, lease and rental plans, please contact your local Terex Cranes Distributor.

We reserve the right to amend these specifications at any time without notice. The only warranty applicable is our standard written warranty applicable to the particular product and sale. We make no other warranty, expressed or implied.

THE ULTIMATE CRANE™

 **TEREX | AMERICAN**

WILMINGTON OPERATIONS
202 Raleigh Street
Wilmington, NC 28412 USA
(910) 395-8500 • FAX: (910) 395-8538
E-mail: american@american-crane.com

www.terex-cranes.com

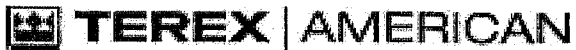

Model HC110 Crawler Crane - Ratings In Pounds
 59HI Offset Tip Boom - 4 Sheave Tip
 52,900 Pound Upper Counterweight
 23,000 Pound Sideframe Counterweight
 Sideframes Fully Extended - w/ Extenders In Place

BOOM LENGTH	RADIUS (FEET)	BOOM ANGLE (DEGREES)	360 DEGREE RATING (POUNDS)	FROM BOOM POINT TO GROUND (FEET)
50' BOOM	13	79.9	220,000 *	56
	15	77.6	190,080 *	55
	20	71.6	123,290	54
	25	65.4	87,670	52
	30	58.9	67,640	49
	35	51.9	54,900	46
	40	44.1	46,010	41
	50	22.7	34,480	26
60' BOOM	14	80.7	203,570 *	66
	15	79.7	189,950 *	65
	20	74.8	123,100	64
	25	69.7	87,490	63
	30	64.5	67,430	61
	35	59.1	54,700	58
	40	53.3	45,790	54
	50	40.0	34,250	45
	60	20.6	27,130	27
70' BOOM	16	80.3	177,910 *	75
	20	77.0	122,950	75
	25	72.8	87,320	73
	30	68.4	67,250	71
	35	63.9	54,530	69
	40	59.2	45,620	67
	50	49.0	34,050	59
	60	36.9	26,960	48
	70	19.0	22,070	29
80' BOOM	17	80.8	161,850	85
	20	78.7	122,740	85
	25	75.0	87,130	84
	30	71.2	67,020	82
	35	67.4	54,310	80
	40	63.4	45,380	78
	50	55.0	33,810	72
	60	45.7	26,730	64
	70	34.4	21,840	52
	80	17.7	18,300	31
90' BOOM	19	80.6	133,440	95
	20	79.9	122,580	95
	25	76.7	86,970	94
	30	73.4	66,860	93
	35	70.0	54,150	91
	40	66.6	45,210	89
	50	59.4	33,630	84
	60	51.6	26,570	77
	70	42.9	21,670	68
	80	32.3	18,120	55
	90	16.7	15,440	32

BOOM LENGTH	RADIUS (FEET)	BOOM ANGLE (DEGREES)	360 DEGREE RATING (POUNDS)	FROM BOOM POINT TO GROUND (FEET)
100' BOOM	20	80.9	122,380	105
	25	78.0	86,760	104
	30	75.1	66,630	103
	35	72.1	53,930	102
	40	69.0	44,980	100
	50	62.7	33,380	95
	60	56.0	26,340	89
	70	48.8	21,430	82
	80	40.6	17,880	71
	90	30.6	15,190	57
	100	15.8	13,090	34
110' BOOM	22	80.7	105,050	115
	25	79.1	86,580	114
	30	76.5	66,410	113
	35	73.8	53,720	112
	40	71.0	44,760	110
	50	65.4	33,160	106
	60	59.5	26,130	101
	70	53.2	21,220	94
	80	46.4	17,650	86
	90	38.6	14,960	75
	100	29.1	12,860	60
	110	15.1	11,180	35
120' BOOM	24	80.5	91,640	125
	25	80.1	86,370	125
	30	77.6	66,180	124
	35	75.2	53,490	122
	40	72.7	44,530	121
	50	67.6	32,910	117
	60	62.3	25,890	113
	70	56.7	20,970	107
	80	50.8	17,410	99
	90	44.3	14,720	90
	100	36.9	12,600	78
	110	27.9	10,910	62
	120	14.4	9,540	36
130' BOOM	25	80.8	86,180	135
	30	78.6	65,990	134
	35	76.3	53,300	133
	40	74.0	44,340	131
	50	69.4	32,700	128
	60	64.6	25,690	124
	70	59.6	20,770	118
	80	54.3	17,210	112
	90	48.6	14,510	104
	100	42.4	12,400	94
	110	35.4	10,700	82
	120	26.7	9,310	65
	130	13.8	8,160	37

BOOM LENGTH	RADIUS (FEET)	BOOM ANGLE (DEGREES)	360 DEGREE RATING (POUNDS)	FROM BOOM POINT TO GROUND (FEET)
140' BOOM	27	80.7	76,660	145
	30	79.4	65,750	144
	35	77.3	53,070	143
	40	75.2	44,100	142
	50	70.9	32,450	139
	60	66.5	25,450	135
	70	62.0	20,530	130
	80	57.2	16,960	124
	90	52.2	14,260	117
	100	46.8	12,140	108
	110	40.8	10,440	98
	120	34.0	9,050	85
	130	25.7	7,890	67
140	13.3	6,920	39	
150' BOOM	28	80.9	72,450	154
	30	80.1	65,530	154
	35	78.2	52,860	153
	40	76.2	43,870	152
	50	72.2	32,220	149
	60	68.2	25,230	146
	70	64.0	20,300	141
	80	59.6	16,730	136
	90	55.1	14,020	129
	100	50.3	11,910	122
	110	45.1	10,210	113
	120	39.4	8,810	102
	130	32.8	7,640	88
140	24.9	6,670	69	
150	12.8	5,840	40	
160' BOOM	30	80.7	65,300	164
	35	78.9	52,640	163
	40	77.1	43,640	162
	50	73.4	31,960	160
	60	69.6	24,990	156
	70	65.7	20,060	152
	80	61.7	16,480	147
	90	57.6	13,770	141
	100	53.2	11,650	134
	110	48.6	9,950	126
	120	43.6	8,550	117
	130	38.1	7,380	105
	140	31.8	6,400	91
150	24.0	5,550	72	
160	12.4	4,850	41	

BOOM LENGTH	RADIUS (FEET)	BOOM ANGLE (DEGREES)	360 DEGREE RATING (POUNDS)	FROM BOOM POINT TO GROUND (FEET)
170' BOOM	31	80.9	62,050	174
	35	79.6	52,430	174
	40	77.9	43,420	173
	50	74.4	31,740	170
	60	70.8	24,780	167
	70	67.2	19,850	163
	80	63.5	16,270	159
	90	59.7	13,560	153
	100	55.7	11,430	147
	110	51.5	9,730	139
	120	47.0	8,320	131
	130	42.2	7,150	121
	140	36.9	6,160	108
	150	30.8	5,320	93
	160	23.3	4,600	74
	170	12.1	3,990	42
180' BOOM	33	80.8	56,790	184
	35	80.2	52,200	184
	40	78.6	43,200	183
	50	75.3	31,490	180
	60	71.9	24,560	178
	70	68.6	19,600	174
	80	65.1	16,020	170
	90	61.5	13,310	165
	100	57.8	11,180	159
	110	54.0	9,470	152
	120	49.9	8,070	144
	130	45.6	6,890	135
	140	41.0	5,900	124
	150	35.8	5,060	112
	160	29.9	4,330	96
	170	22.6	3,690	76
180	11.7	3,150	43	
190' BOOM	34	81.0	52,440 *	194
	35	80.7	51,980	194
	40	79.2	42,970	193
	50	76.1	31,260	191
	60	72.9	24,330	188
	70	69.7	19,370	185
	80	66.5	15,790	181
	90	63.2	13,070	176
	100	59.7	10,940	170
	110	56.2	9,230	164
	120	52.4	7,820	157
	130	48.5	6,650	149
	140	44.3	5,660	139
	150	39.8	4,810	128
	160	34.8	4,070	115
	170	29.1	3,430	99
180	22.0	2,880	78	
190	11.4	2,410	44	



Model HC110 Crawler Crane - Ratings In Pounds
 59HI Offset Tip Boom - 4 Sheave Tip
 52,900 Pound Upper Counterweight
 23,000 Pound Sideframe Counterweight
 Sideframes Fully Extended - w/ Extenders In Place

BOOM LENGTH	RADIUS (FEET)	BOOM ANGLE (DEGREES)	360 DEGREE RATING (POUNDS)	FROM BOOM POINT TO GROUND (FEET)
200' BOOM	36	80.9	46,580 *	204
	40	79.7	42,730	203
	50	76.8	31,010	201
	60	73.8	24,090	198
	70	70.8	19,130	195
	80	67.7	15,540	191
	90	64.6	12,820	187
	100	61.4	10,690	182
	110	58.0	8,980	176
	120	54.6	7,570	169
	130	51.0	6,390	162
	140	47.2	5,390	153
	150	43.1	4,540	143
	160	38.8	3,800	132
	170	33.9	3,170	118
180	28.3	2,610	101	
190	21.5	2,120	80	
200	11.1	1,700	45	
210' BOOM	38	80.8	41,260 *	214
	40	80.2	40,530 *	213
	50	77.4	30,780	211
	60	74.6	23,870	209
	70	71.7	18,910	206
	80	68.8	15,320	202
	90	65.9	12,600	198
	100	62.9	10,470	193
	110	59.7	8,750	188
	120	56.5	7,340	182
	130	53.2	6,160	174
	140	49.7	5,170	166
	150	46.0	4,310	157
	160	42.0	3,570	147
	170	37.8	2,920	135
180	33.0	2,360	121	
190	27.6	1,860	104	

BOOM LENGTH	RADIUS (FEET)	BOOM ANGLE (DEGREES)	360 DEGREE RATING (POUNDS)	FROM BOOM POINT TO GROUND (FEET)
220' BOOM	39	80.9	36,220 *	224
	40	80.7	35,920 *	223
	50	78.0	30,530	222
	60	75.3	23,640	219
	70	72.6	18,670	216
	80	69.8	15,080	213
	90	67.1	12,350	209
	100	64.2	10,220	204
	110	61.3	8,490	199
	120	58.2	7,090	193
	130	55.1	5,900	187
	140	51.9	4,900	179
	150	48.5	4,050	171
	160	44.9	3,300	162
170	41.0	2,650	151	
180	36.9	2,090	138	
190	32.3	1,590	124	
230' BOOM	41	80.8	31,600 *	233
	50	78.5	27,960 *	232
	60	76.0	23,410	230
	70	73.4	18,440	227
	80	70.8	14,840	224
	90	68.1	12,110	220
	100	65.4	9,970	215
	110	62.6	8,250	211
	120	59.8	6,830	205
	130	56.8	5,660	199
	140	53.8	4,660	192
	150	50.6	3,800	184
	160	47.3	3,060	175
	170	43.8	2,410	166
180	40.1	1,840	154	

 **WARNING**

This rating chart is invalid if the crane has been modified or altered by use of other than GENUINE AMERICAN PARTS as such modifications or alterations may affect its capacity or safe operation. See American Crane Corporation Service Bulletin #259.

Ratings in this chart are in POUNDS and do not exceed the percentage of tipping specified for this crane by ANSI B30.5. All ratings require that the crane be standing level on a firm uniformly supporting surface.

Do not lift loads in excess of those shown on this chart. Lifting loads in excess of those shown or operation not in accordance with good operating practice, including limitations shown on page 3499 of Operator's Manual, can cause tipping, structural damage or catastrophic failure.

Asterisk (*) areas on this chart indicate ratings that are limited by strength of material or factors other than stability (tipping).

" RADIUS IN FEET " is the horizontal distance at ground level from the crane centerline of rotation to a vertical line through the center of gravity of the suspended load.

When using the main boom fall with jib in place, the main fall ratings must be reduced by the jib effective weight shown on the jib rating chart plus twice the weight of all suspended blocks, slings, rope, etc., at the jib fall. See Appendix A.

When using the main boom fall with boom tip extension in place, the main fall ratings must be reduced by the weight of the boom tip extension plus twice the weight of all suspended blocks, slings, rope, etc., at the boom tip extension fall. See Appendix A.

Blocks, slings, buckets and other load carrying devices are considered part of the load. The weight of standard hoisting ropes for the rating at a given radius has been calculated as part of the boom point load and need not be considered in determining net allowable loads. See Appendix A.

This chart was developed exclusively for use with a boom only. Under no circumstances are these ratings to be interpreted for use with a jib.

Ratings shown on this chart make no allowance for such factors as out of plumb loads, wind, poor soil conditions, improper inflation of rubber tires and dynamic effects due to excessive operating speeds. The user (operator) must exercise judgment to make allowance for these conditions. See page 3499 of Operator's Manual for detailed information.

No account is taken of the wind force on the load. The user must consider this effect, which can be substantial for loads with large surface areas. In any wind it is strongly recommended that taglines be used to control the load.

BOOM HOIST LINE –

12 parts of 3/4 inch diameter IPS wire rope with a minimum breaking strength of 51,200 pounds

PENDANT SUSPENSION LINE –

2 parts of 1-3/8 inch diameter EEIPS wire rope with a minimum breaking strength of 211,000 pounds.

MAIN LOAD LINE –

1.000 inch diameter EIPS wire rope with a minimum breaking strength of 103,400 pounds or
0.875 inch diameter EIPS wire rope with a minimum breaking strength of 79,600 pounds

SIDEFRAME POSITION DEFINITIONS

These ratings are valid for the sideframe positions as indicated below. Refer to the *HC110 Operator's Manual* for additional information.

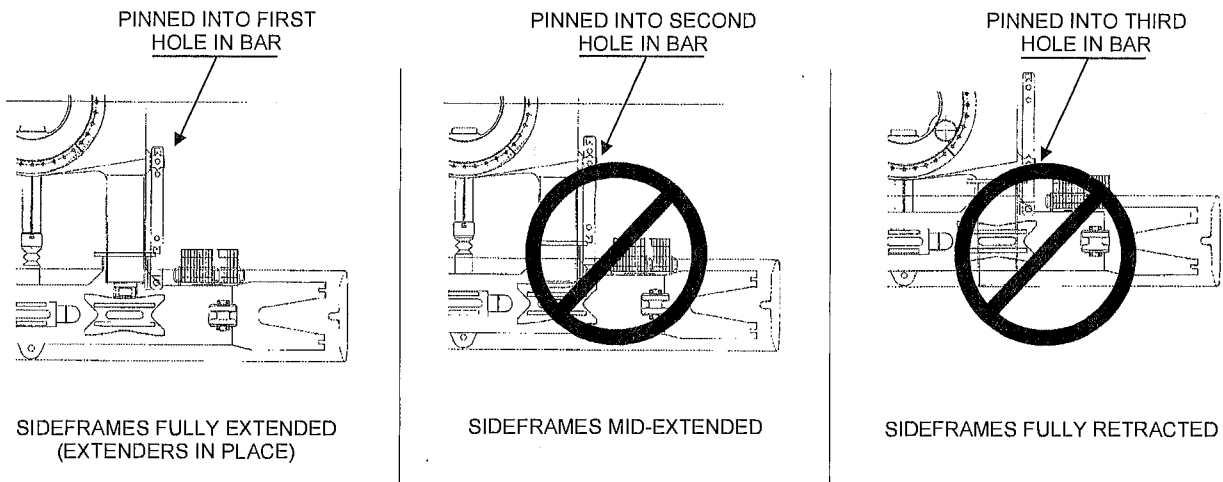

ERECTION

Erection "OVER-THE-END BLOCKED" is with the boom over the idler end with idler tumblers blocked (See *HC110 Operator's Manual* for blocking instructions). Erection "OVER-THE-SIDE" is with the boom 90° to the sideframes. Blocks, slings and other load carrying devices must be on the ground during erection.

59HI OFFSET TIP BOOM MAXIMUM BOOM & JIB SELF-ERECTION DATA				
JIB	OVER-THE-END BLOCKED		OVER-THE-SIDE	
			SIDEFRAMES FULLY-EXTENDED (WITH EXTENDERS IN PLACE)	
	BOOM LENGTH (FEET)	JIB LENGTH (FEET)	BOOM LENGTH (FEET)	JIB LENGTH (FEET)
9HL	230	0	210	0
	220	0	200	0
	210	40	190	40
	200	70	180	70

LOAD HOISTING INFORMATION - 1.00" diameter EIPS wire rope			
MAXIMUM LIFTING CAPACITY - LBS.	MINIMUM PARTS OF LINE	MAXIMUM HOISTING DISTANCE - FEET	
		MAIN HOIST	AUX HOIST
220,000	8	130	NOT APPLICABLE
206,800	7	148	
177,250	6	173	
147,700	5	208	
118,150	4	260	
88,600	3	346	
59,050	2	520	
29,500	1	1040	

LOAD HOISTING INFORMATION - 7/8" diameter EIPS wire rope			
MAXIMUM LIFTING CAPACITY - LBS.	MINIMUM PARTS OF LINE	MAXIMUM HOISTING DISTANCE - FEET	
		MAIN HOIST	AUX HOIST
181,900	8	NOT APPLICABLE	78
159,200	7		89
136,450	6		104
113,700	5		125
90,950	4		156
68,200	3		208
45,450	2		313
22,700	1		626

BOOM COMPOSITION CHART - 59HI OFFSET TIP					
BOOM LENGTH (FEET)	BOOM SECTIONS				
	25' 59HI INNER	10' 59H CENTER	20' 59H CENTER	40' 59H CENTER	25' 59HI OUTER
50	1	0	0	0	1
60	1	1	0	0	1
70	1	0	1	0	1
80	1	1	1	0	1
90	1	0	0	1	1
100	1	1	0	1	1
110	1	0	1	1	1
120	1	1	1	1	1
130	1	0	0	2	1
140	1	1	0	2	1
150	1	0	1	2	1
160	1	1	1	2	1
170	1	0	0	3	1
180	1	1	0	3	1
190	1	0	1	3	1
200	1	1	1	3	1
210	1	0	0	4	1
220	1	1	0	4	1
230	1	0	1	4	1